

# User Instructions

## CMOD 34 Spreader Frame

**Modulift**<sup>®</sup>  
working between the hook and the load

The CMOD Spreader Frame is modular in span and every frame consists of 4 Corner Units, with intermediate Struts that can be bolted into the assembly to achieve different spans. CMOD 34 has an assembled span ranging from 1m by 1m to 8m by 8m and all spans inbetween.

### Assembled Frame

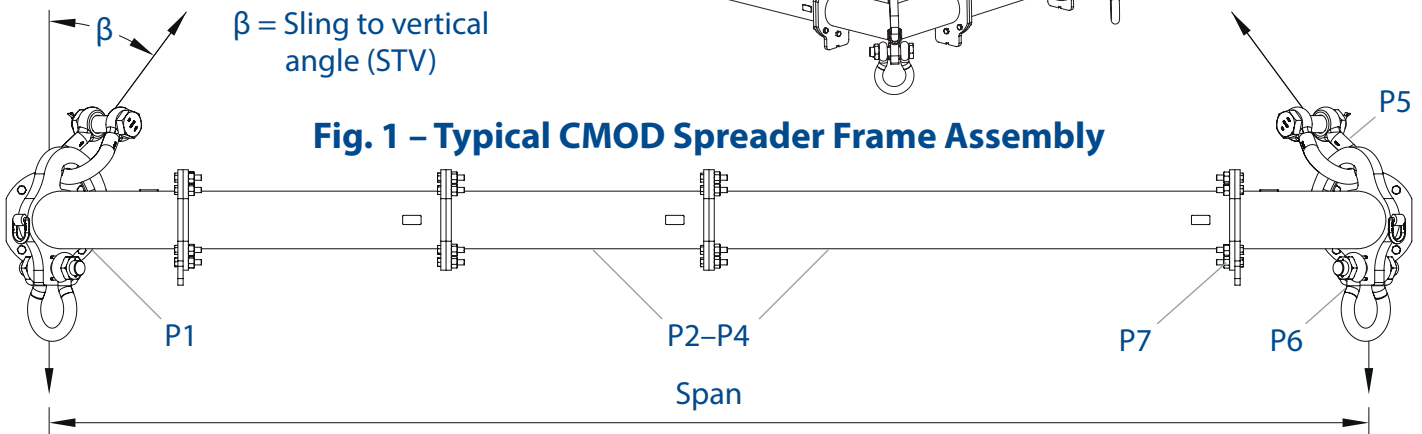
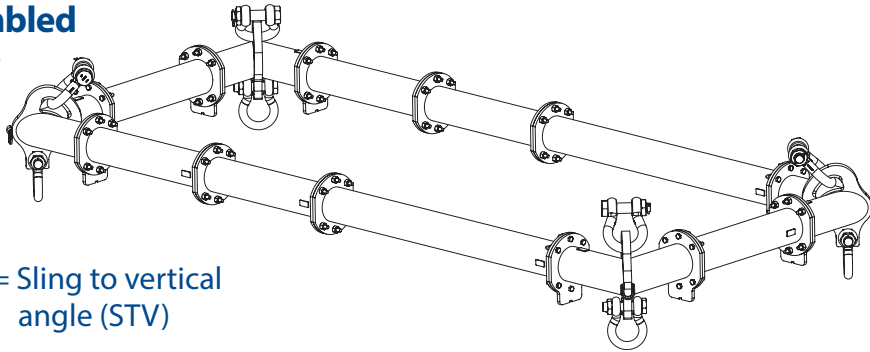

### Strut

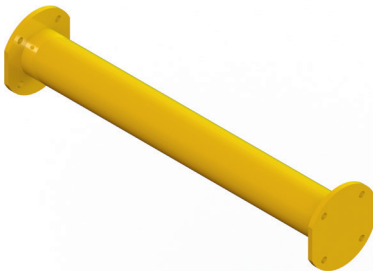

### Corner Unit



### Table 1 – Component List

Part Ref.	Description	Weight/item
P1	Corner Unit (length 0.5m each)	50kg
P2	2.0m Strut	51kg
P3	1.0m Strut	31kg
P4	0.5m Strut	20kg
P5	25t Shackle	14kg
P6	17t Shackle	8kg
P7	M20 x 50, Grade 8.8, HT Bolts, Nuts & Washers	

### CMOD 34 Frame Specification

- Rated at a maximum of 40 tonnes WLL. Please see **Table 2** for WLL at specific spans.
- 'Sling to Vertical' angle,  $\beta$ , 45 degrees or less.
- Corner Units are rated at 10 tonnes each (40 tonnes combined capacity).
- **Bolt tightening torque: 150Nm.** Spanner size required: 30mm.
- Recommended additional equipment: Torque Wrench, Podger Spanner and Ring Spanner.

### ⚠ WARNING!

- Personnel using this system should be suitably trained, competent and have a clear understanding of Safe Slings procedures.
- The use of Modulift equipment must be in accordance with the procedures laid down in 'Lifting Operations and Lifting Equipment Regulations 1998' (LOLER).
- **Never exceed stated WLL** – Adhere to WLL in **Table 2** for particular sling angle used.
- **The top sling length is critical to the safe use of the spreader** – Ensure you refer to the correct table.

# User Instructions

## CMOD 34 Spreader Frame

**Modulift**<sup>®</sup>  
working between the hook and the load

### **WARNING!**

- Do not under any circumstances hang load(s) from the tube or flanges – the Spreader Frame is designed for compression – not bending.
- Ensure that the top Shackle contacts the bow of the corner plate 'bow-to-bow'.
- The CMOD system is designed in accordance with BS EN13155: Cranes, Safety, Non- fixed Load Lifting Attachments.
- **Max number of Struts allowed in assembly: 5 per side**
- **Assemble longer Struts in the centre of the configuration**
- **Sling angle is crucial to safe use of frame.**
- **The top sling must be positioned centrally in the Shackle pin to ensure even loading. Contact your Modulift supplier for supply of loose spacers where required.**

### Do's & Don'ts

- Do ensure that the frame is only loaded at the Corner Units and they are all equally loaded.
- Do ensure enough clearance between frame and the load to prevent the load hitting the frame. Any collision could cause failure of the frame.
- Do not undertake a lift without the correct use of appropriate top slings.
- Do not hang any loads from the Strut tube or flanges.
- Do not exceed the stated WLL for your span.
- Do not rig the lower slings more than 6° from vertical.

### Assembly Procedure

- Check the ID plates on each Modulift component to ensure the correct size is used.
- Lay out the Struts and Corner Units in the correct configuration.
- Check that all flanges are clear from debris, sand etc. before connection.
- Bolt the components together\* using bolts, nuts & washers provided. Tighten the bolts to torque as shown overleaf.
- Loop the top Shackles through the bows of the Corner Units so they contact 'bow-to-bow'. The eye of the top slings can then be passed through the jaws of the Shackles and the pins replaced.
- Loop the bottom Shackles through the eyes of the drop slings and connect to the bottom of the Corner Unit with the Shackle pin.
- Attach the lower slings to the load to be lifted.
- The assembled Spreader Frame and lifting rig must be thoroughly checked by a competent person prior to lifting.

\*The use of a Podger Spanner will aid in assembly by helping to align the bolt holes by forcing it through.

CMOD 34 UK NOV 2022  
© Copyright 2022 Modulift.  
All rights reserved.

Should you find your equipment is no longer of use, please dispose of in a responsible manner. Please contact Modulift if you need further guidance



### Table 2 – Load v Span

First pick the span required for your frame (e.g. 2m x 5m) and the Sling Angle (we recommend 30° STV where possible), then check the WLL via the appropriate table. Read the table by locating the lower span on the y axis of the chart and the larger on the x. The cell which you are referred to, will indicate the WLL for your chosen span. If your exact span is not noted in the table, then please round up or down to the values that will give you the lowest WLL (to ensure no overloads are applied). Please contact Modulift for confirmation on your WLL if required. WLL given in tonnes.

#### CMOD 34: WLL / tonnes @ 30° STV

8								24
7							32	23
6						40	31	22
5					40	40	28	20
4				40	40	34	26	19
3			40	40	40	34	24	18
2		40	40	40	40	32	23	17
1	40	40	40	40	34	30	22	16
Span (m)	1	2	3	4	5	6	7	8

#### CMOD 34: WLL / tonnes @ 45° STV

8								13
7							18	13
6						22	17	12
5					27	22	16	11
4				27	27	19	15	10
3			27	27	25	19	13	10
2		27	27	27	22	18	13	9
1	27	27	27	27	19	17	12	9
Span (m)	1	2	3	4	5	6	7	8

# CMOD Sling length guide

## 30° STV

To be read in conjunction with appropriate CMOD User Instructions.

23																							32.5
22																					31.1	31.8	
21																			29.7	30.4	31.1		
20																	28.3	29.0	29.7	30.5			
19															26.9	27.6	28.3	29.1	29.8				
18													25.5	26.2	26.9	27.7	28.4	29.2					
17											24.0	24.8	25.5	26.2	27.0	27.8	28.6						
16									22.6	23.3	24.1	24.8	25.6	26.4	27.2	28.0							
15							21.2	21.9	22.7	23.4	24.2	25.0	25.8	26.6	27.5								
14					19.8	20.5	21.3	22.0	22.8	23.6	24.4	25.2	26.1	26.9									
13			18.4	19.1	19.8	20.6	21.4	22.2	23.0	23.9	24.7	25.6	26.4										
12		17.0	17.7	18.4	19.2	20.0	20.8	21.6	22.5	23.3	24.2	25.1	25.9										
11		15.6	16.3	17.0	17.8	18.6	19.4	20.2	21.1	22.0	22.8	23.7	24.6	25.5									
10		14.1	14.9	15.6	16.4	17.2	18.0	18.9	19.7	20.6	21.5	22.4	23.3	24.2	25.1								
9		12.7	13.5	14.2	15.0	15.8	16.6	17.5	18.4	19.2	20.1	21.0	21.9	22.8	23.8	24.7							
8		11.3	12.0	12.8	13.6	14.4	15.3	16.1	17.0	17.9	18.8	19.7	20.6	21.5	22.5	23.4	24.4						
7		9.9	10.6	11.4	12.2	13.0	13.9	14.8	15.7	16.6	17.5	18.4	19.3	20.2	21.2	22.1	23.1	24.0					
6		8.5	9.2	10.0	10.8	11.7	12.5	13.4	14.3	15.2	16.2	17.1	18.0	19.0	19.9	20.9	21.8	22.8	23.8				
5		7.1	7.8	8.6	9.4	10.3	11.2	12.1	13.0	13.9	14.9	15.8	16.8	17.7	18.7	19.6	20.6	21.6	22.6	23.5			
4		5.7	6.4	7.2	8.1	8.9	9.8	10.8	11.7	12.6	13.6	14.6	15.5	16.5	17.5	18.4	19.4	20.4	21.4	22.4	23.3		
3		4.2	5.0	5.8	6.7	7.6	8.5	9.5	10.4	11.4	12.4	13.3	14.3	15.3	16.3	17.3	18.2	19.2	20.2	21.2	22.2	23.2	
2		2.8	3.6	4.5	5.4	6.3	7.3	8.2	9.2	10.2	11.2	12.2	13.2	14.1	15.1	16.1	17.1	18.1	19.1	20.1	21.1	22.1	23.1
1	1.4	2.2	3.2	4.1	5.1	6.1	7.1	8.1	9.1	10.0	11.0	12.0	13.0	14.0	15.0	16.0	17.0	18.0	19.0	20.0	21.0	22.0	23.0
Span (m)	1	2	3	4	5	6	7	8	9	10	11	12	13	14	15	16	17	18	19	20	21	22	23

### WARNING!

If the CoG of the load is central, then all top slings can be sized at the above lengths.

If the CoG is offset then this should be accounted for by resizing the top slings.

**Please contact Modulift directly if you are unsure of how to proceed.**

# CMOD Sling length guide

## 45° STV

To be read in conjunction with appropriate CMOD User Instructions.

23																							23.0
22																					22.0	22.5	
21																			21.0	21.5	22.0		
20																	20.0	20.5	21.0	21.6			
19															19.0	19.5	20.0	20.6	21.1				
18													18.0	18.5	19.0	19.6	20.1	20.7					
17											17.0	17.5	18.0	18.6	19.1	19.7	20.2						
16									16.0	16.5	17.0	17.6	18.1	18.7	19.2	19.8							
15							15.0	15.5	16.0	16.6	17.1	17.7	18.2	18.8	19.4								
14					14.0	14.5	15.0	15.6	16.1	16.7	17.3	17.8	18.4	19.0									
13			13.0	13.5	14.0	14.6	15.1	15.7	16.3	16.9	17.5	18.1	18.7										
12			12.0	12.5	13.0	13.6	14.1	14.7	15.3	15.9	16.5	17.1	17.7	18.3									
11			11.0	11.5	12.0	12.6	13.2	13.7	14.3	14.9	15.5	16.1	16.8	17.4	18.0								
10			10.0	10.5	11.0	11.6	12.2	12.7	13.3	13.9	14.6	15.2	15.8	16.4	17.1	17.7							
9			9.0	9.5	10.0	10.6	11.2	11.8	12.4	13.0	13.6	14.2	14.9	15.5	16.2	16.8	17.5						
8			8.0	8.5	9.1	9.6	10.2	10.8	11.4	12.0	12.6	13.3	13.9	14.6	15.2	15.9	16.6	17.2					
7			7.0	7.5	8.1	8.6	9.2	9.8	10.4	11.1	11.7	12.3	13.0	13.7	14.3	15.0	15.7	16.3	17.0				
6			6.0	6.5	7.1	7.6	8.2	8.9	9.5	10.1	10.8	11.4	12.1	12.7	13.4	14.1	14.8	15.4	16.1	16.8			
5			5.0	5.5	6.1	6.7	7.3	7.9	8.5	9.2	9.8	10.5	11.2	11.9	12.5	13.2	13.9	14.6	15.3	16.0	16.6		
4			4.0	4.5	5.1	5.7	6.3	7.0	7.6	8.3	8.9	9.6	10.3	11.0	11.7	12.3	13.0	13.7	14.4	15.1	15.8	16.5	
3			3.0	3.5	4.1	4.7	5.4	6.0	6.7	7.4	8.1	8.7	9.4	10.1	10.8	11.5	12.2	12.9	13.6	14.3	15.0	15.7	16.4
2	2.0	2.5	3.2	3.8	4.5	5.1	5.8	6.5	7.2	7.9	8.6	9.3	10.0	10.7	11.4	12.1	12.8	13.5	14.2	14.9	15.6	16.3	
1	1.0	1.6	2.2	2.9	3.6	4.3	5.0	5.7	6.4	7.1	7.8	8.5	9.2	9.9	10.6	11.3	12.0	12.7	13.5	14.2	14.9	15.6	16.3
Span (m)	1	2	3	4	5	6	7	8	9	10	11	12	13	14	15	16	17	18	19	20	21	22	23



### WARNING!

If the CoG of the load is central, then all top slings can be sized at the above lengths.

If the CoG is offset then this should be accounted for by resizing the top slings.

**Please contact Modulift directly if you are unsure of how to proceed.**

## 1. Manufacturer's Contact Details

Modulift UK Ltd  
Cordite House, 4 Holton Point, Holton Heath  
Trading Park, Poole, Dorset, BH16 6FL,  
Website: [www.modulift.com](http://www.modulift.com)  
E-mail: [info@modulift.com](mailto:info@modulift.com) Tel.: +44 1202 621511

## 2. Introduction

These supplementary instructions are an original instruction in accordance with section 1.7.4 (Instructions and Annex II Declarations) of the EC Machinery Directive 2006/42/EC, and are to be read in conjunction with Modulift's User Instructions that accompany Generic products, and/or in conjunction with the GA Drawing(s) issued for job-specific custom designs.

## 3. EC declaration of conformity

With reference to the EC Declaration of Conformity accompanying all new Modulift products, the declaration is also referenced below:

We declare that the CE-marked products described in these supplementary user instructions are in compliance with the essential requirements and fulfil all the relevant provisions of the Directive 2006/42/EC, and as a minimum in conformance with the following harmonized standards / applied technical standards:

- BS EN 13155: 2003+A2:2009
- BS EN 1993-1-1: 2005

The products can be incorporated as part/s of a CE-marked lifting assembly but must in that case not be put into service until the final lifting assembly has been declared in conformity with the provisions of the Directive 2006/42/EC.

Our management system complies with ISO 9001:2015 / ISO 14001: 2015 / ISO 45001: 2018 and is certified by DNV – Business Assurance (Certificate no. 176391-2015-AIMS-GBR-UKAS valid until 1st April 2024)

If the products are modified without approval from Modulift UK Ltd, this declaration becomes invalid, and used at user's own risk.

Poole, 12.05.20



Technical Representative: Sue Spencer

## 4. Markings

Modulift products have an engraved stainless steel I.D. plate containing key information welded to each component. However, there are some small components that are not physically big enough to have a plate welded to them, therefore the key information is engraved directly onto the component.

In accordance with the directive 2006/42/EC section 1.7.3, all components are marked with:

- CE mark
- Modulift's website address (contact details)
- Product name and/or size/designation
- WLL (note: for products that have varying WLL's depending on the assembled configuration, the WLL is referenced in a table in the specific User Instructions)
- Unique identification serial number
- Year of manufacture
- Self weight of component

Additional marking are permitted, provided that it is applied using low stress punches on the I.D. plates, or applied as labels.

## 5. Intended use

Modulift products are generally items used for Lifting i.e. lifting accessories. These products must only be used for their intended use, as per the detailed User Instructions / GA Drawing accompanying these products. For example, a Spreader Beam designed for compression forces must never be used as a Lifting Beam which is designed for bending forces. Detailed technical data and intended use can be found on the specific User Instructions / GA Drawings specific to the product.

Temperature rating of Modulift main generic products: rated to -20°C to 60°C. Custom products may differ, to be stated on certificate.

Fatigue: Fatigue failure can occur even if the



WLL has not been exceeded. Scenarios in which the product is subjected to variable load over a prolonged period of time, will carry the risk of inducing fatigue. Consider this when deciding service intervals.

The rating of lifting accessories in European Standards assumes the absence of exceptionally hazardous conditions. Exceptionally hazardous conditions include offshore activities, the lifting of persons and lifting of potentially dangerous loads such as molten metals, corrosive materials or fissile materials. In such cases the degree of hazard should be assessed by a competent person and the working load limit adjusted accordingly.

## 6. Assembly

Generally, Modulift products are used as part of a lifting rig used in lifting operations. Lifting rigs tend to contain many different types of lifting accessories interconnected.

Modulift are experts in designing and manufacturing modular products, that need assembly prior to use. Follow the User Instructions regarding assembly, paying particular attention to ensuring bolts, nuts & washers are tightened to the required tightening torques.

Additional rigging accessories such as slings are usually either connected directly to the Modulift product, or via connection shackles and other accessories. These additional rigging accessories manufactured by other manufacturers will have their own User Instructions and EC declarations, refer to these specific instructions/declarations and ensure these rigging accessories are properly assembled & used.

## 7. User instructions

Modulift's products must only be used after reading and understanding the specific User Instruction(s).

## 8. Lifting: Planning and Operations

It is required by law that any company undertaking a lifting operation must ensure it is planned and carried out according to a safe system of work. Requirements may vary from country to country, but should as a minimum follow the following guidelines:

All lifting operations must be planned by a suitably trained and experienced competent person.

Planning a lifting operation should include:

- Risk Assessment – identifying all hazards and mitigating the risk
- Method Statement – step-by-step guide for onsite personnel to follow
- Determining complexity of lift rating
- Details of qualified personnel to be involved in the lift e.g. slinger/signaller, lift supervisor, riggers
- Detailed force calculations used to determine correct sizing of lifting equipment being used in the rig
- Details of sling lengths to ensure the hook is directly over the CoG
- Sizing of slings to take into account offset CoG as there will be higher forces on the heavy side
- Accuracy of weight and CoG position of the items to be lifted – by calculation or weighing
- Safety factor applied to the weight of the skids being lifted
- Stability calculation: the CoG is above the connection points in the top skid – check for toppling
- Site details, permissible floor loadings, access etc.
- P.P.E. for all personnel
- Name of qualified AP (Appointed Person) that has prepared the lift plan, and their contact details in case of issues

All operators to follow safe sling procedures and to be suitably trained and experienced, competent persons. Operators must check equipment WLL for the specific configurations against the plan / rig drawing.

A competent person must check the rig prior to commencing the lift. The path of the load that it will be maneuvered through must be checked for obstacles. The safety of other persons not involved in the lift must be considered. Any deviations to the planned lift must be discussed and agreed with the person responsible planning the lift.

Modulift UK Ltd are not responsible for planning the lift and are not liable in any way for the advice stated above.

## 9. Inspection prior to each use

The manufacturer's EC Declarations of conformity certificate must be found to be in order for all equipment, and that the Modulift product(s) is/are precisely as ordered.

Before each use the Modulift product(s) must be inspected for obvious damage or deterioration.

The inspection should be done in accordance with local regulations. If there is any doubt with regards to these criteria being met, the product(s) must not be used for a lifting operation. Modulift are able to provide inspection guidance if required.

## 10. General instructions for safe use

General comments for lifting rigs:

- Do not exceed the stated WLL of the Modulift product at the required configuration (see UI)
- - Do not exceed the WLL of the specific connection point on the product, consider the position of the CoG of the load being lifted
- - Top sling STV for spreaders must not be greater than 45 degrees / greater than the specified STV – top sling length is crucial.
- - Check the stability of the rig design – if the CoG of the load is above its connection points – see example opposite:
- Ensure that the rig is designed so that the CoG of the item being lifted is directly below the hook point, otherwise the rig will tilt and could overload lifting equipment.
- - Ensure the load being lifted is strong enough to be lifted in the proposed method.
- - All equipment within the rig must be of a suitable capacity.
- - The rig should be checked by a competent person prior to commencing lifting to ensure it is correct as per the rig drawing, and everything is securely fastened.

### B > A = Stable

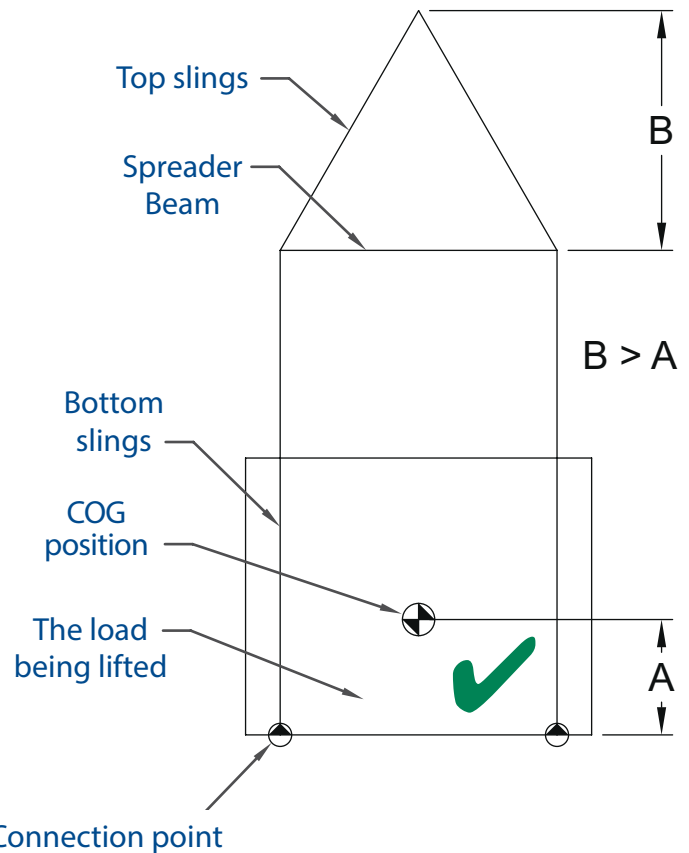

### B < A = Unstable

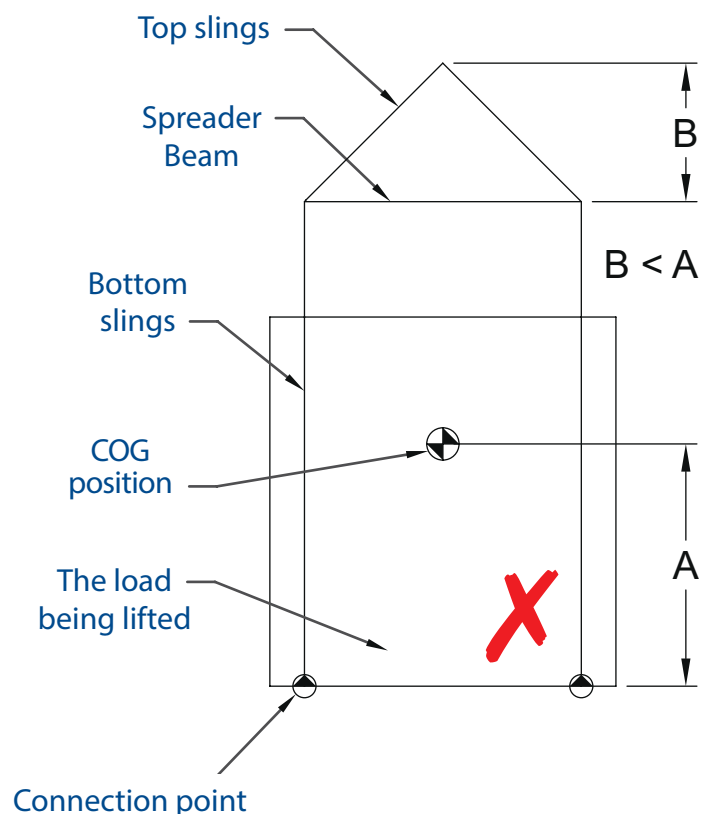

## 11. Thorough examination

A thorough examination should be carried out by a competent person at intervals not exceeding six months, and at sooner intervals in accordance with local laws or where the equipment is used in extreme environments.

Components that have cracks, are visibly distorted or twisted, severely corroded, or have gouges in excess of 10% of the thickness of the material should be discarded and replaced, or repaired. The thorough examination should be carried out by a competent inspector.

Fasteners should be inspected prior to each use, and discarded if any visible damage to the bolt shank or the thread.

## 12. Repair

Repairs must be done by Modulift if possible, but in exceptional circumstances repairs can be done by a third party in strict accordance with Modulift's requirements & express approval.

It is essential that Modulift is contacted to discuss any repairs before proceeding, otherwise the Modulift declaration becomes invalid.

## 13. End of life

Modulift products are generally made from structural mild steel that can be widely recycled.